

Torque tools calibration station

up to 400 Nm



**Mechanical
Loader**



**ST Series
Transducer**



**Readout
Unit**

ST Series Transducer

- Dedicated for transducers from up to 400 Nm
- Allows quick change of transducers with various measurement ranges



BMS Readout unit

- Dedicated to work with BMS transducers
- Enables real-time reading of the set torque
- Built-in memory for up to 5,000 measurement results
- Allows data readout and report creation using dedicated software

Torque tool holder

- Enables precise leveling of the tool on the station
- Provides a solid and stable reaction point during the calibration process



Professional bench for mechanical torque application

- Made entirely of aluminum and high-quality steel.
- Mechanism ensures smooth torque application on the tested tool.
- Lever below the control rail is moved precisely with a linear, high-accuracy bearing knob.
- The calibrated torque wrench remains stationary in the same position throughout the calibration, eliminating errors caused by shifting the force application point.

Technical details	
Range	up to 400 Nm
Length (L)	106.9 cm
Width (b)	70.4 cm
Height (h)	32.3 cm
Weight	44.8 kg
Profile Width	18 cm

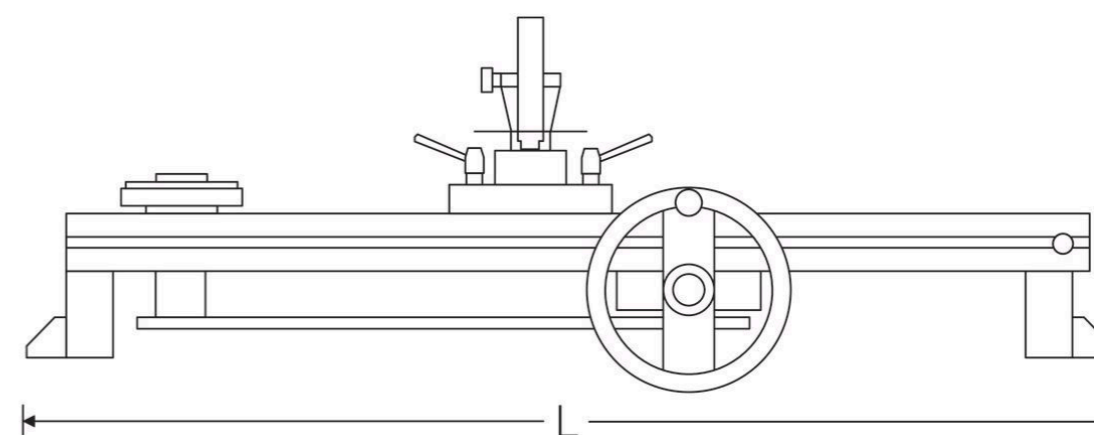
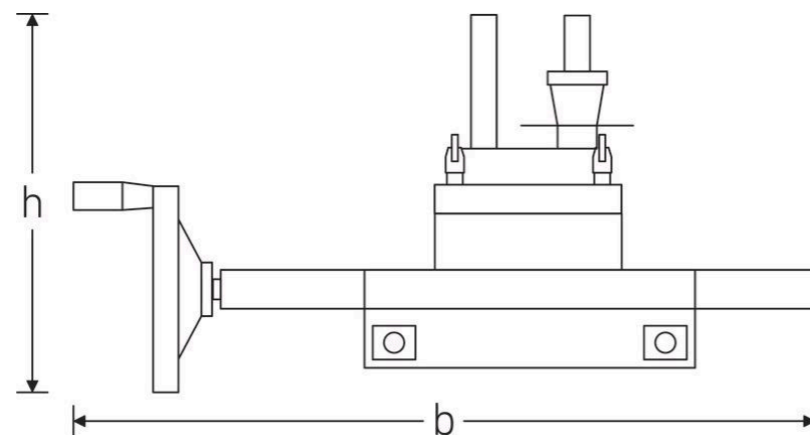

The torque application bench is dedicated to operate with BMS ST-series transducers. It has been designed for professional users - laboratories and production facilities - where periodic inspection and adjustment of torque wrenches are critical. It enables precise leveling of tools during the verification/calibration process. The bench provides stable mounting of the transducer and ensures a fixed, unchanged position of the wrench throughout the entire process, eliminating errors caused by shifts in the force application point. **During calibration/verification, the wrench remains stationary while the transducer performs a rotational movement. The transducer is driven by a strong and highly durable crank mechanism.**

The bench is intended for use with BMS transducers with ranges up to 400 Nm and allows quick replacement of transducers with different measurement ranges - matched to the ranges of the wrenches being tested - which significantly increases flexibility and efficiency. The readout unit enables real-time monitoring of measured parameters and storage of the obtained results in internal memory, making it easy to generate reports and results in the dedicated Frank software.

The bench, manufactured entirely from aluminum and high-grade steel, together with its precision mechanism and stable reaction point, ensures not only durability but also operator comfort. The professional mechanical torque application bench allows smooth and controlled loading of the tested tools, while the adjustable reaction point guarantees high measurement accuracy regardless of the wrench length. The bench is an ideal solution for any user requiring calibration of torque wrenches and other measuring tools, while maintaining the highest standards of precision and repeatability in accordance with ISO 6789.

